

CHRONOFLASH 35 A

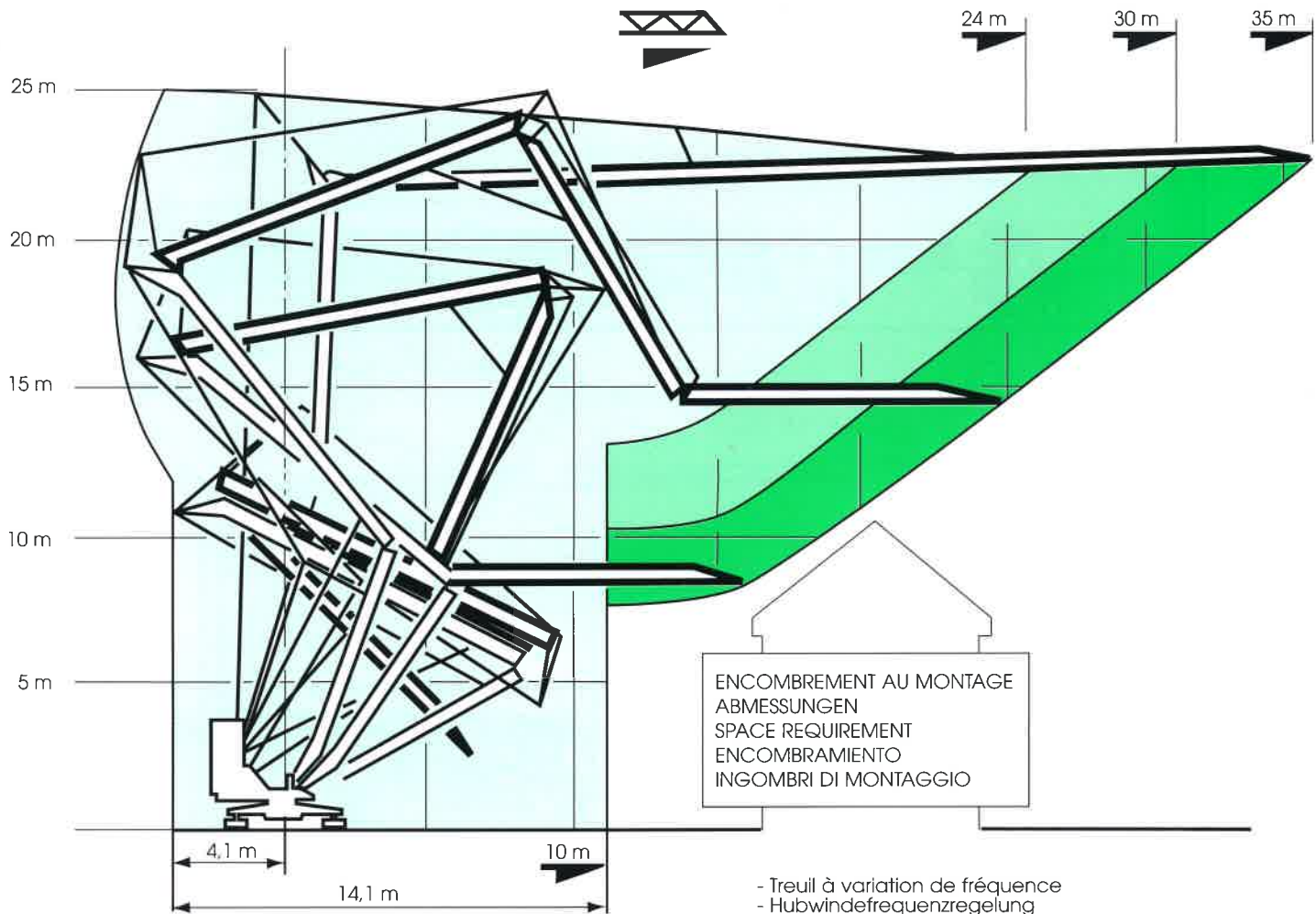

- Treuil à variation de fréquence
- Hubwindefrequenzregelung
- Frequency variation hoist winch
- Motor de elevación con variación de frecuencia
- Argano di sollevamento con variatore di frequenza

CHRONOFLASH 35 A		m/mn	KW	ch PS-HP	kg		
	I	3,5	3,7	5	4000		
	II	10,5	11	15	4000		
	III	21	11	15	2500		
	I	7	3,7	5	2000		
	II	21	11	15	2000		
	III	42	11	15	1250		
	tr/mn U/mn		Rpm V/mn	0,2 >>> 0,4 >>> 0,9	2,2	3	
	I	21	2	2,7			
	II	42					
		0 > > 25	2 x 1	2 x 1,4			
	V	380	450				
	Hz	50	60				
	KVA	20	24				

	m/mn	KW	ch PS-HP	kg
I	2,5	3,7	5	4000
II	12,5	11	15	4000
III	25	15	20	2700
I	5	3,7	5	2000
II	25	11	15	2000
III	50	15	20	1350

GRUPE ELECTROGENE STROMAGGREGAT GENERATOR SET GRUPO ELECTROGENO GRUPPO ELETTOGENO	V	380	450
	Hz	50	60
	KVA	40	48

CHRONOFLASH® 35 A

TRANSPORT
ROUTIER

TRANSPORT
STRASSE

TRANSPORT
ROAD

TRASPORTO
SU STRADA

TRANSPORTE
RUTA

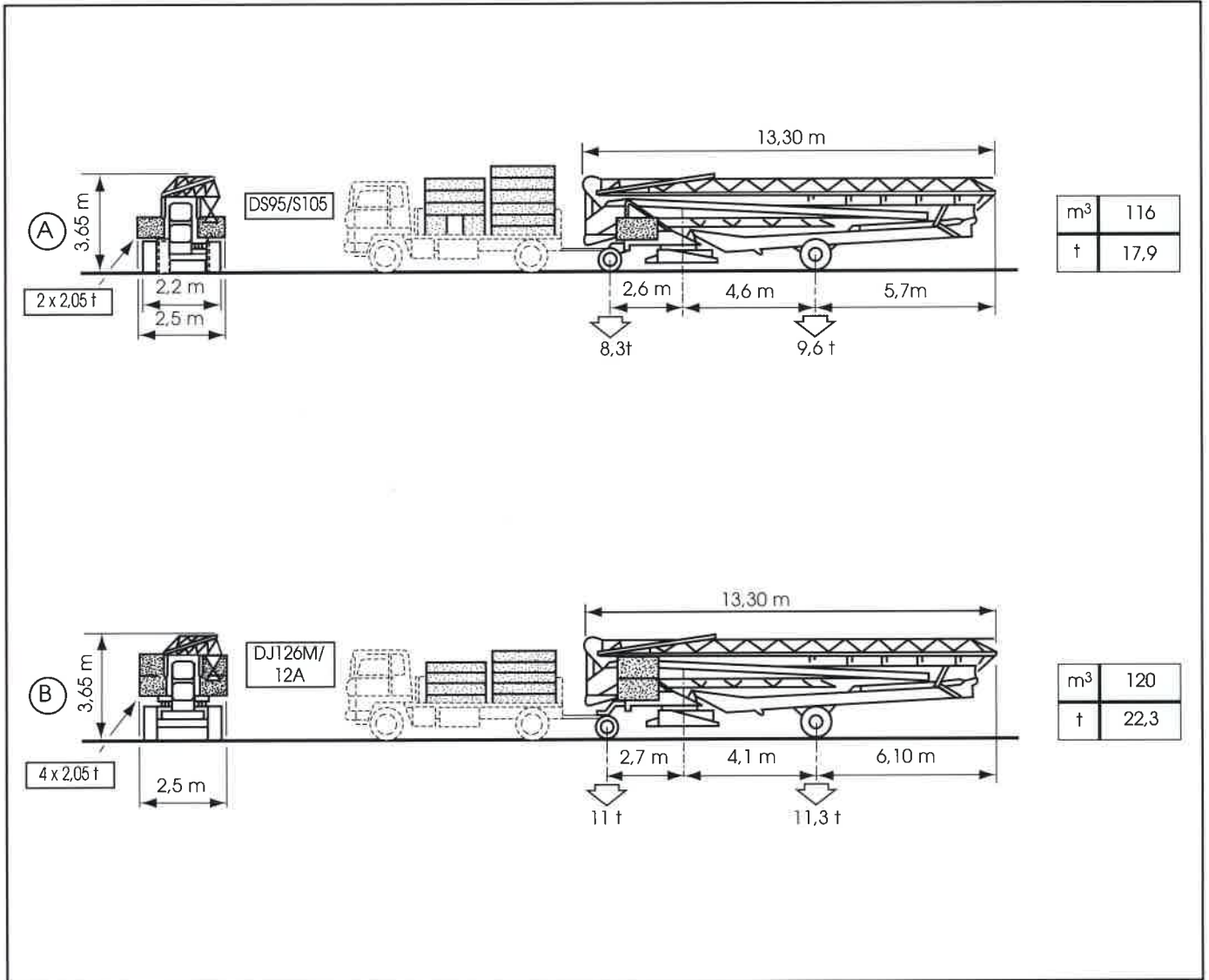

SUR
CAMION

AUF
LKW

ON
LORRY

SU
CAMION

SOBRE
CAMION

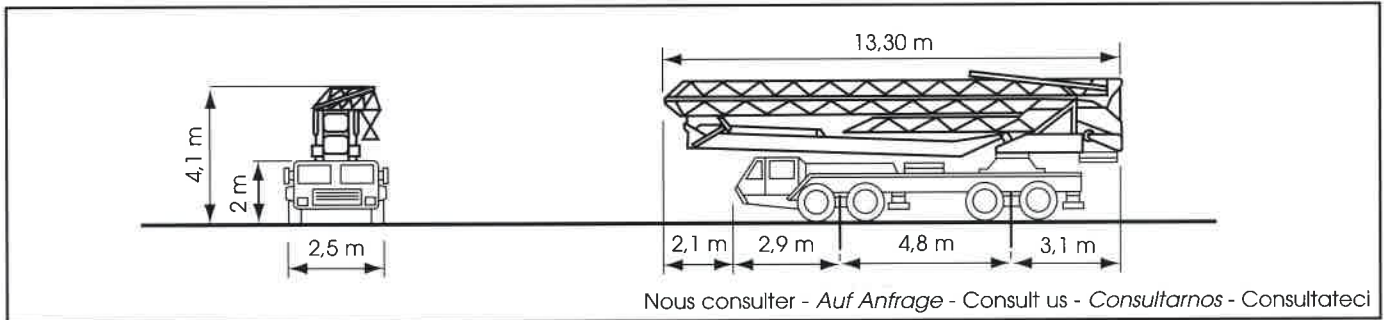

Réf. : 2000.15.LTZ.1



BPR-Cadillon

GRUPE LEGRIS INDUSTRIES

CADILLON Baumaschinen GmbH

Nordendstr. 79-87

64546 Mörfelden-Walldorf

Telefon : 06105 - 704170

Telefax : 06105 - 704159

TURBOBPR.TXT