

# CHRONOFLASH® 25 B

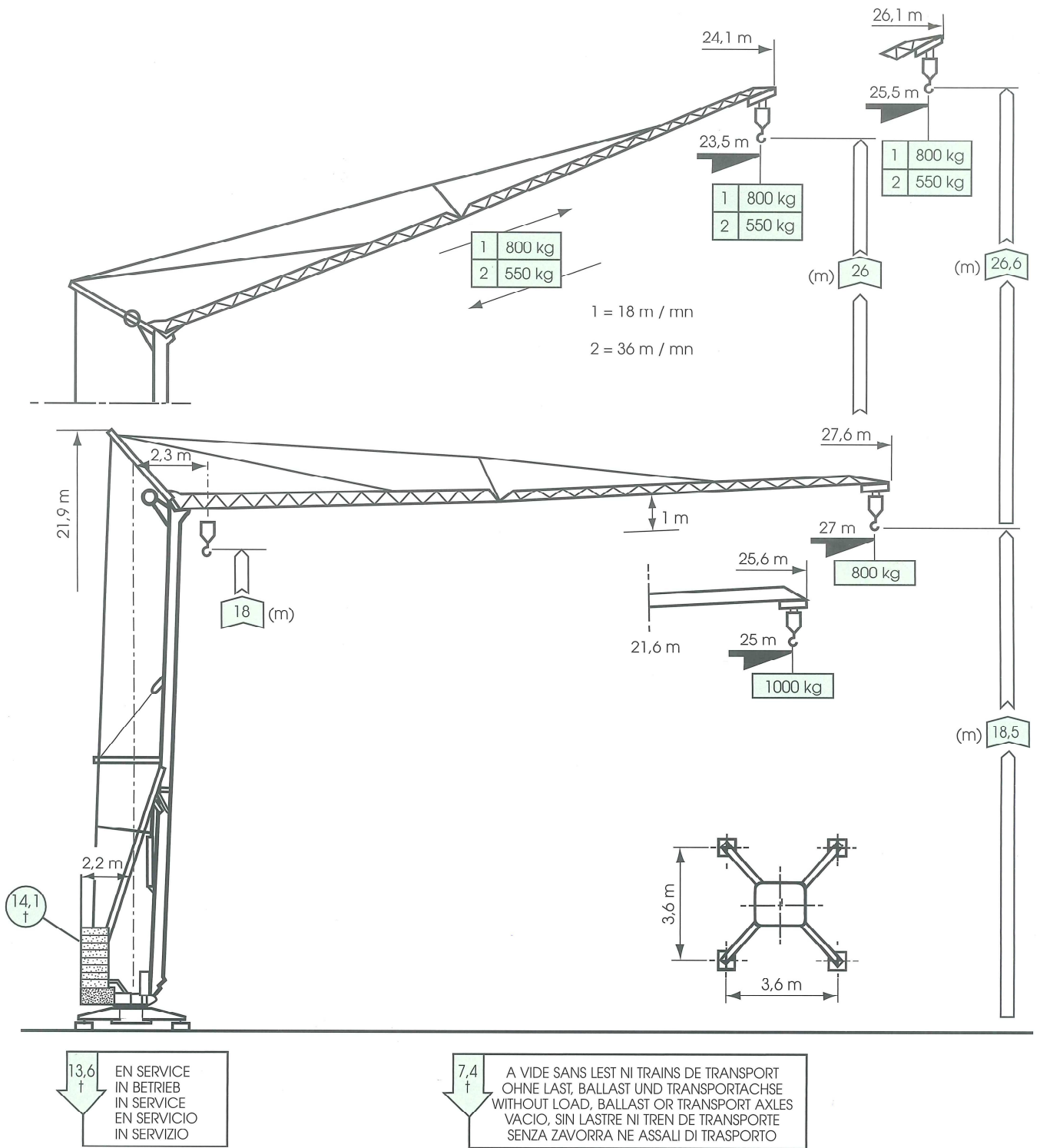

S		CHRONOFLASH 25 B															
		12,8	14	14,1	15	16	17	18	19	20	21	22	23	24	25	26	27
27 m		2000	1790		1645	1520	1410	1315	1230	1160	1090	1030	975	925	880	840	800
25 m				2000	1855	1715	1595	1490	1395	1310	1235	1165	1105	1050	1000	kg	

# CHRONOFLASH® 25 B

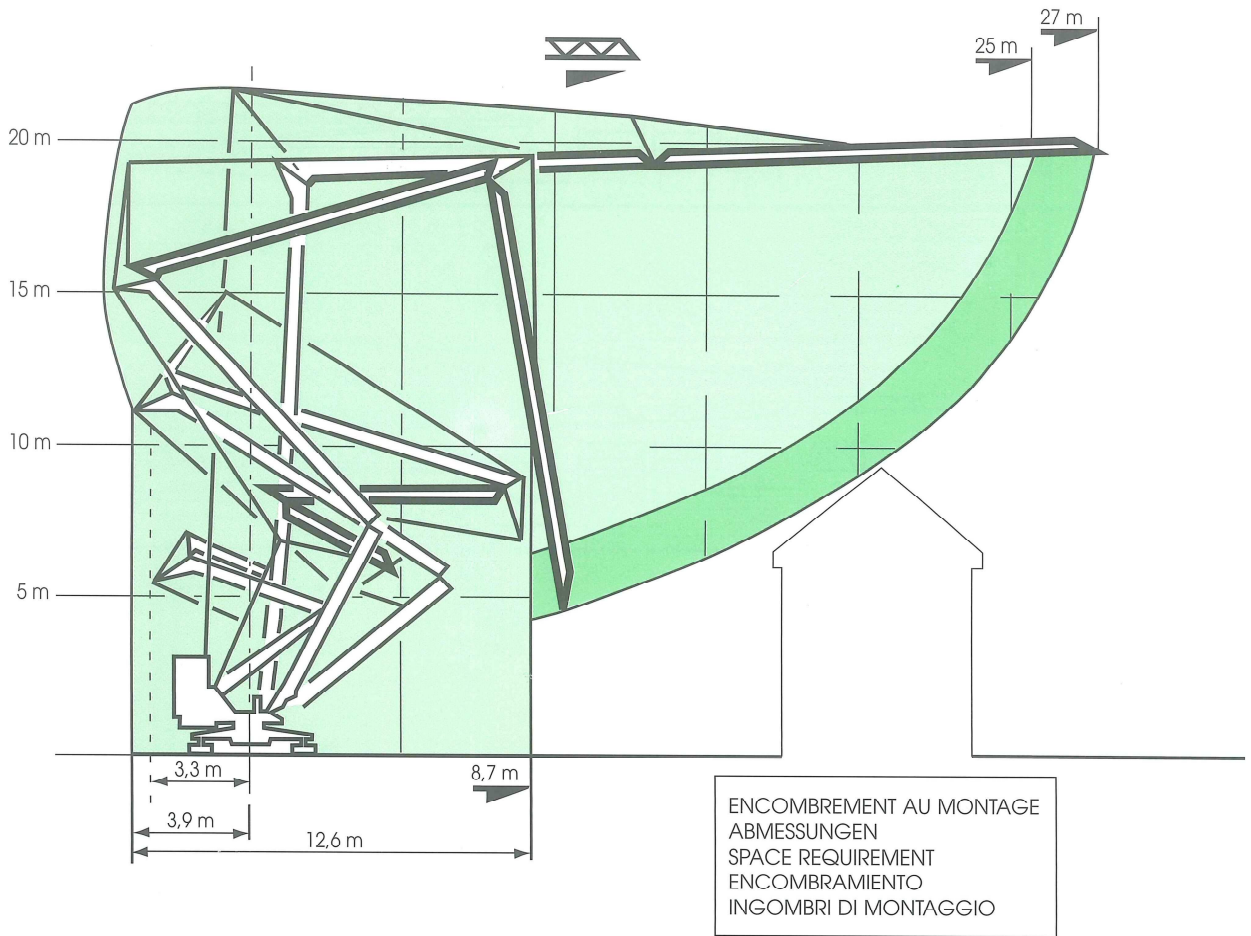

CHRONOFLASH 25 B - 2000 kg		m/mn	KW	ch PS-HP	kg
	I	5	2	2,7	2000
	II	20	6	8,2	2000
	III	40	6	8,2	1000
tr/mn    ↻    Rpm U/mn    □    V/mn		0 >> 0,25 >> 0,9	1,5	2	
		18 - 36	1,5	2	

V	380	450
Hz	50	60
KVA	12	15
GROUPE ELECTROGENE STROMAGGREGAT GENERATOR SET GRUPO ELECTROGENO GRUPPO ELETTROGENO		
KVA	25	30

# CHRONOFLASH® 25 B

TRANSPORT  
ROUTIER

TRANSPORT  
STRASSE

TRANSPORT  
ROAD

TRASPORTO  
SU STRADA

TRANSPORTE  
RUTA

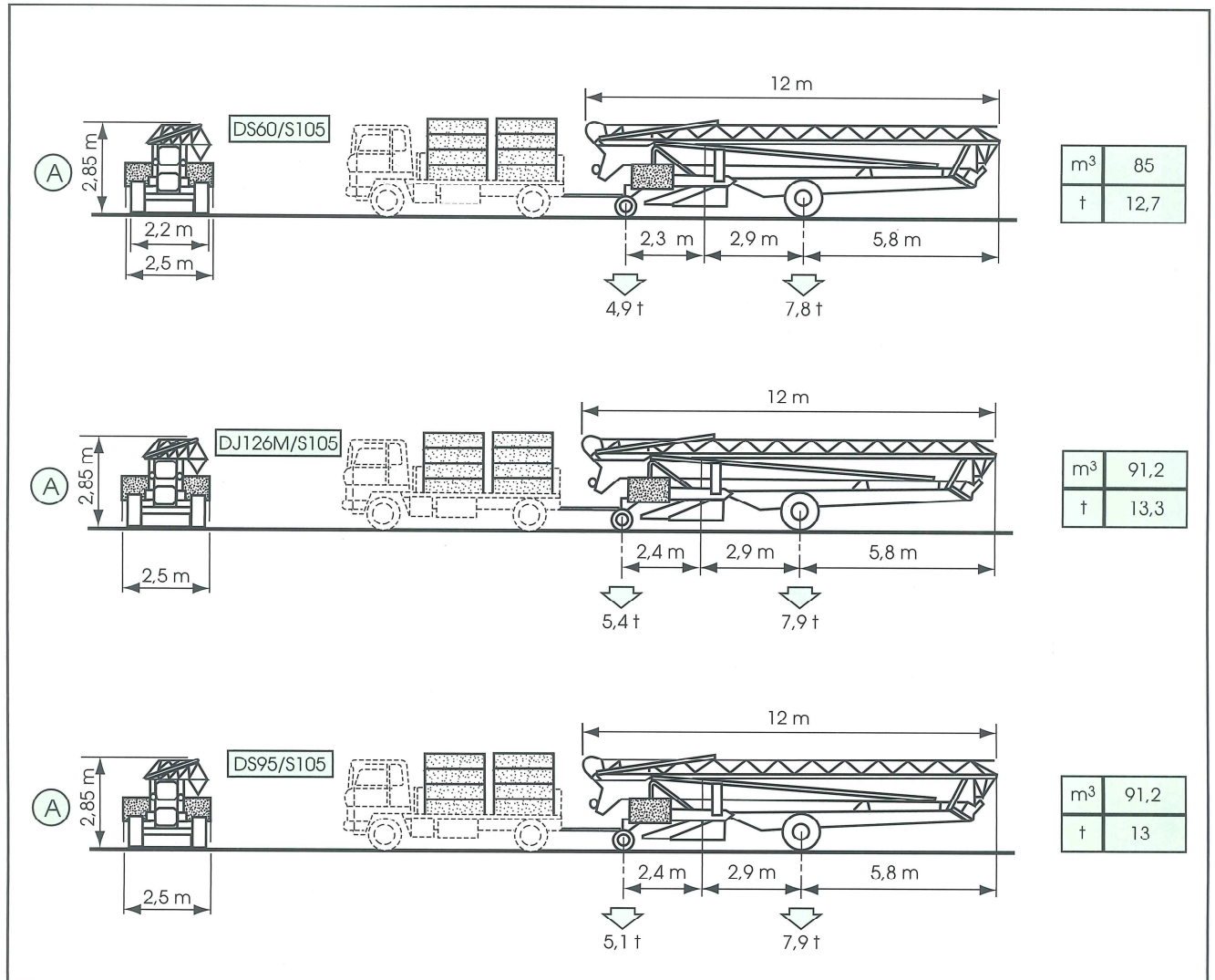

SUR  
CAMION

AUF  
LKW

ON  
LORRY

SU  
CAMION

SOBRE  
CAMION

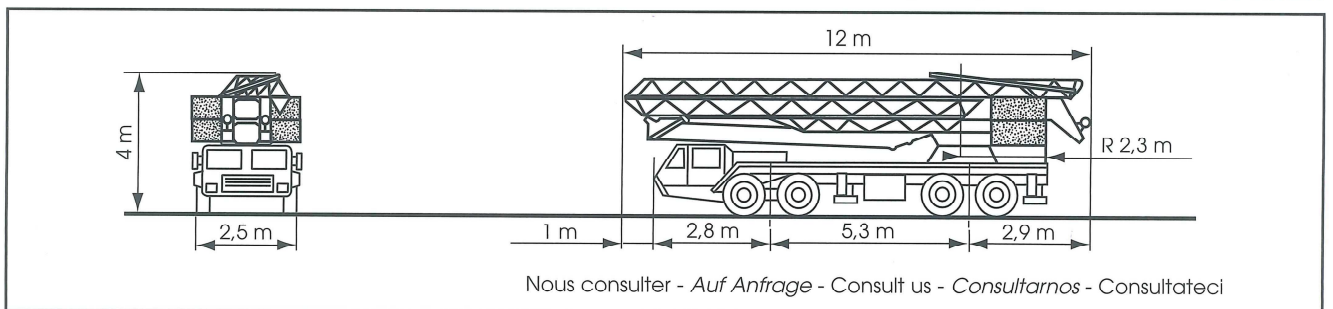

 **BPR-Cadillon**  
 GROUPE LEGRIS INDUSTRIES

CADILLON Baumaschinen GmbH  
 Nordendstr. 79-87  
 64546 Mörfelden-Walldorf  
 Telefon : 06105 - 704170  
 Telefax : 06105 - 704159

Réf. : 2000.15.LTX.1

