

FEM 1.001 - A4
EN 14439 - C25 - D25

Torre/Reazioni – Masts/Reactions – Mat/Réactions – Maste/Eckdrücke – Măstil/Reacciones – Tramo/Reacções

SK1700 FEM

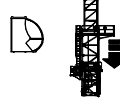
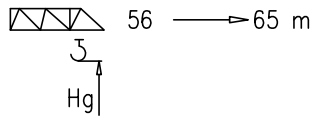

- Hg=Ht-1 m
- Hg=Ht-1.8 m

6	BCF052	2/4
5	BPF117	4/4
4	BPF039	4/4
3	ST117	2/2
2	BAF117	4/2
1	ST039	2/2

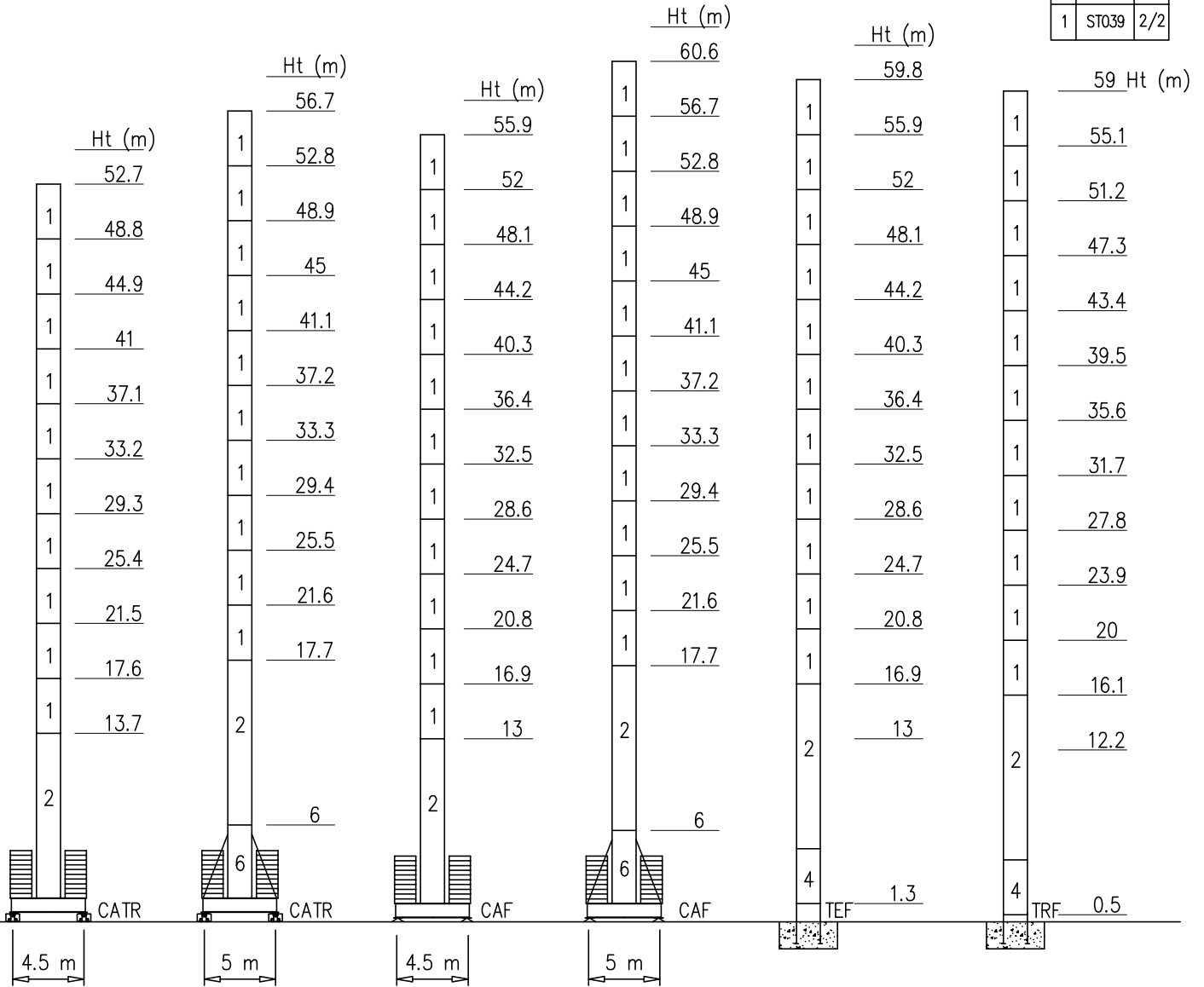

Peso zavorra – Ballast weight – Poids du lest – Ballastgewicht – Peso de lastre

A=3.5 t

SK1700			
H-CATR (m)	41	48.8	52.7
(t)	70	105	126
n'	20xA	30xA	36xA

A=3.5 t

SK1700										
H-CAF (m)	24.7	28.6	32.5	36.4	40.3	44.2	48.1	52	55.9	
(t)	63	63	63	63	63	77	105	119	126	
n'	18xA	18xA	18xA	18xA	18xA	22xA	30xA	34xA	36xA	

C=3.5 t

SK1700		
H-CATR (m)	52.8	56.7
(t)	112.6	126.6
n'	2B+28C	2B+32C

B=7.3 t

C=3.5 t

SK1700								
H-CAF (m)	37.2	41.1	45	48.9	52.8	56.7	60.6	
(t)	63.6	77.6	91.6	105.6	119.6	133.6	140.6	
n'	2B+14C	2B+18C	2B+22C	2B+26C	2B+30C	2B+34C	2B+36C	

B=7.3 t

Torre/Reazioni - Masts/Reactions - Mat/Réactions - Maste/Eckdrücke - Măstil/Reacciones - Tramo/Reacções

SK1700 EN14439-C25

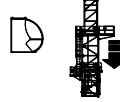
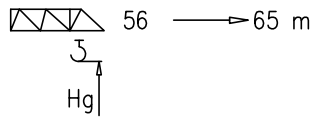

- Hg=Ht-1 m
- Hg=Ht-1.8 m

6	BCF052	2/4
5	BPF117	4/4
4	BPF039	4/4
3	ST117	2/2
2	BAF117	4/2
1	ST039	2/2

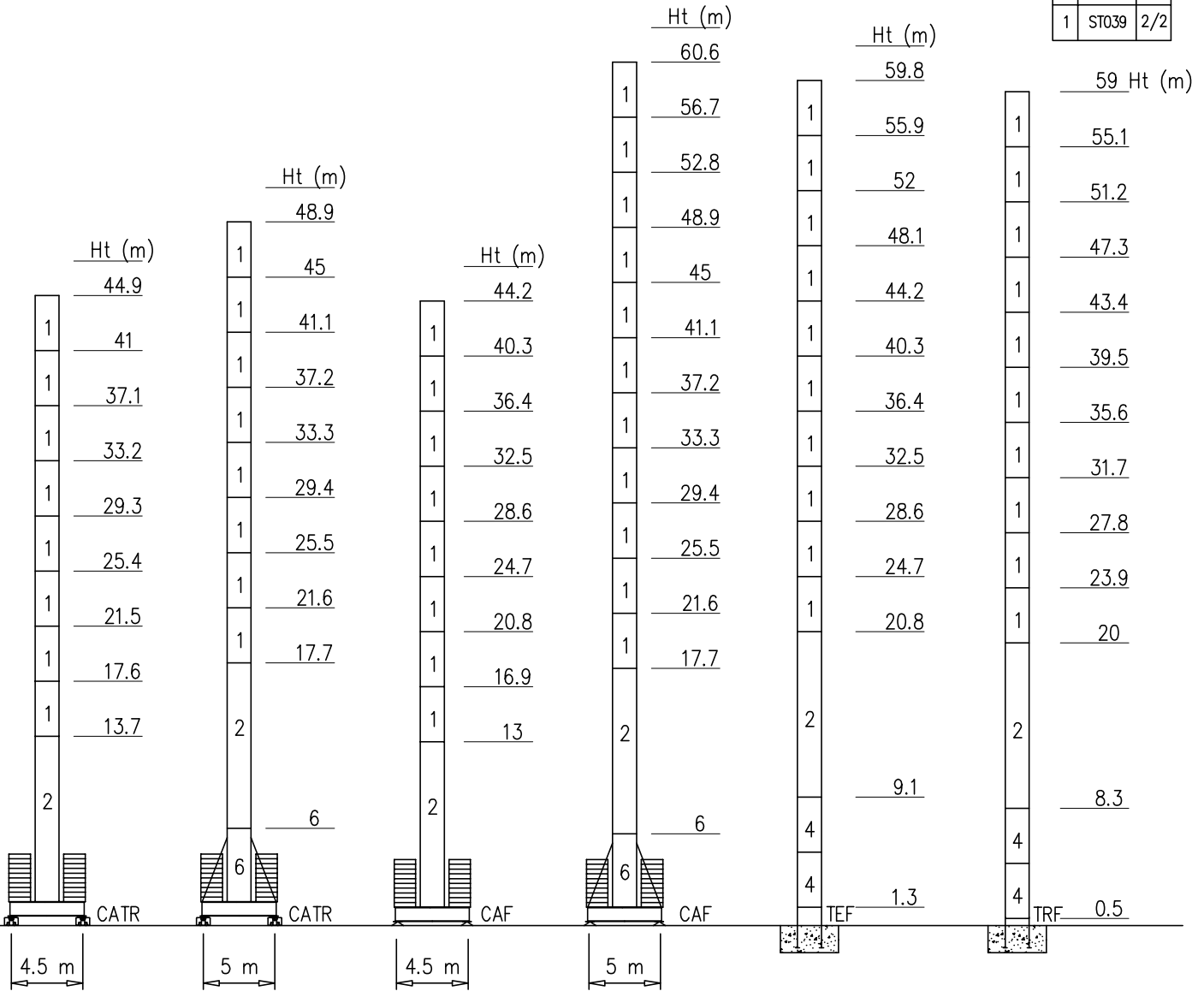

Peso zavorra - Ballast weight - Poids du lest - Ballastgewicht - Peso de lastre

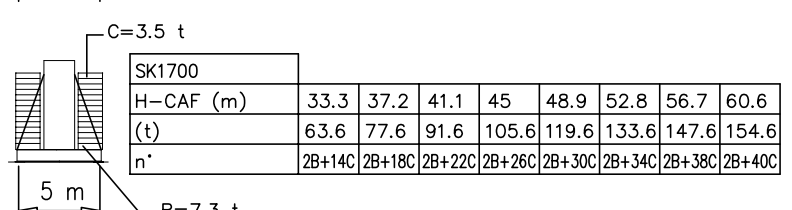
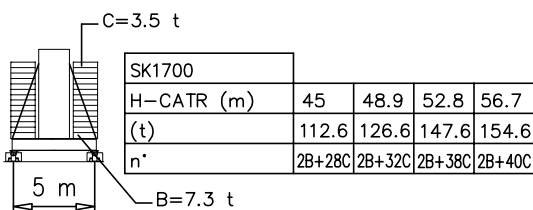
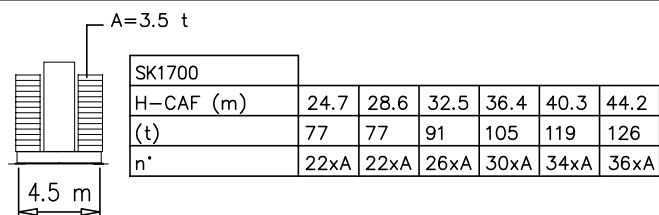
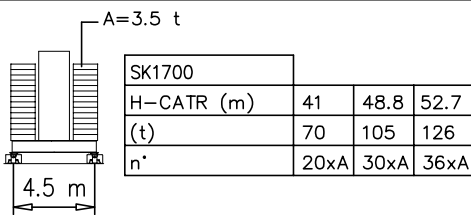

Torre/Reazioni – Masts/Reactions – Mat/Réactions – Maste/Eckdrücke – Măstil/Reacciones – Tramo/Reacções

SK1700 EN14439-D25

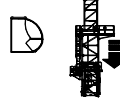
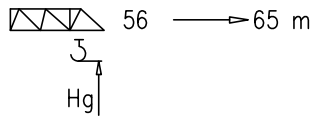

- Hg=Ht-1 m
- Hg=Ht-1.8 m

6	BCF052	2/4
5	BPF117	4/4
4	BPF039	4/4
3	ST117	2/2
2	BAF117	4/2
1	ST039	2/2

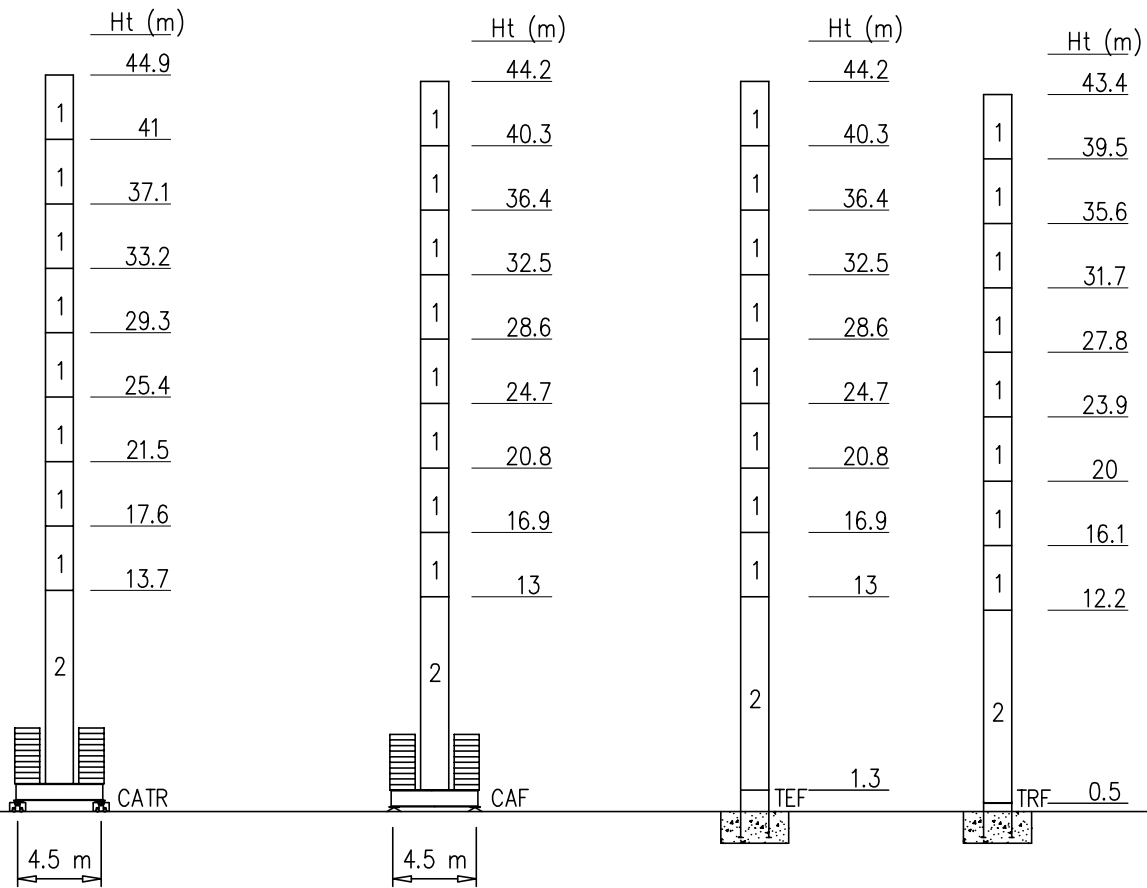

Peso zavorra – Ballast weight – Poids du lest – Ballastgewicht – Peso de lastre

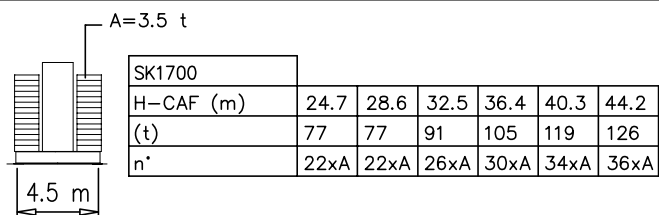
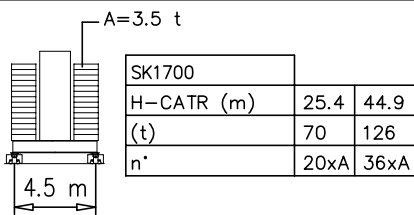

Torre/Reazioni – Masts/Reactions – Mat/Réactions – Maste/Eckdrücke – Măstil/Reacciones – Tramo/Reaçções

SN2050 FEM

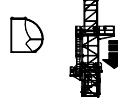
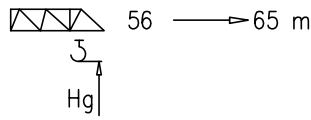

- Hg=Ht-1 m
- ◻ Hg=Ht-1.8 m

14	BCF052	2/4 M45
13	BAF052	2/4 M42
12	BPF117	4/4 M45-45
11	BNF117	4/4 M45-42
10	BOF117	4/4
9	BOF039	4/4
8	BO039	4/4
7	STRO39	2/2
6	SBR117	4/2
5	SBR039	4/2
4	SB117	4/2
3	SB039	4/2
2	ST117	2/2
1	ST039	2/2

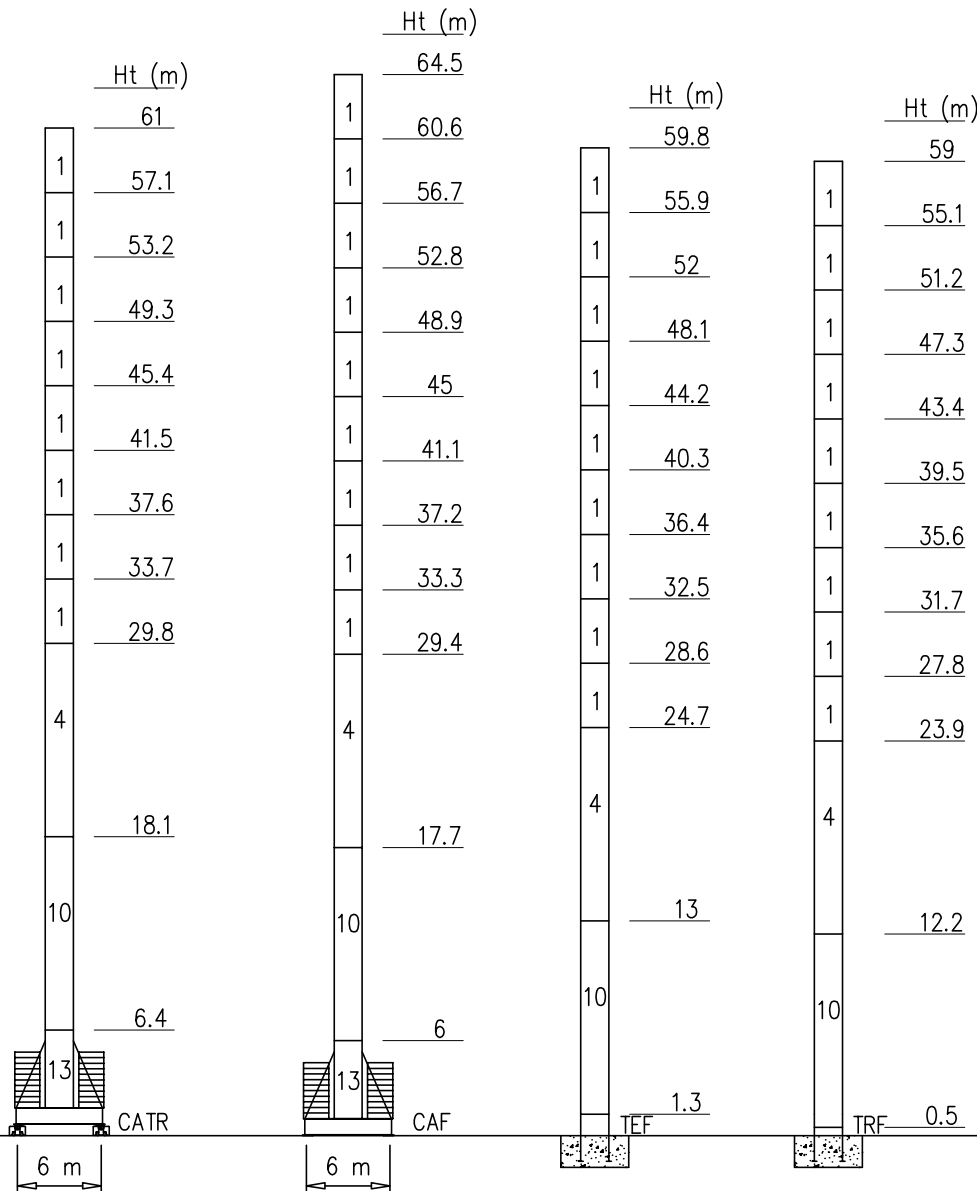

Peso zavorra – Ballast weight – Poids du lest – Ballastgewicht – Peso de lastre

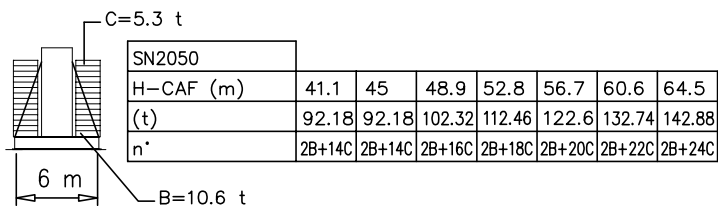
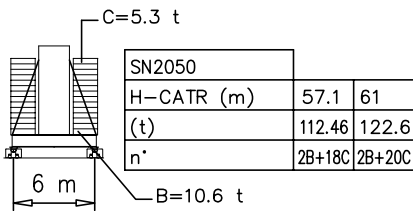

Torre/Reazioni – Masts/Reactions – Mat/Réactions – Maste/Eckdrücke – Măstil/Reacciones – Tramo/Reaçções

SN2050 EN14439-C25

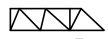
 56 → 65 m

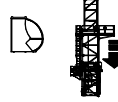

- Hg=Ht-1 m
- ◻ Hg=Ht-1.8 m

Hg

14	BCF052	2/4 M45
13	BAF052	2/4 M42
12	BPF117	4/4 M45-45
11	BNF117	4/4 M45-42
10	BOF117	4/4
9	BOF039	4/4
8	BO039	4/4
7	STR039	2/2
6	SBR117	4/2
5	SBR039	4/2
4	SB117	4/2
3	SB039	4/2
2	ST117	2/2
1	ST039	2/2

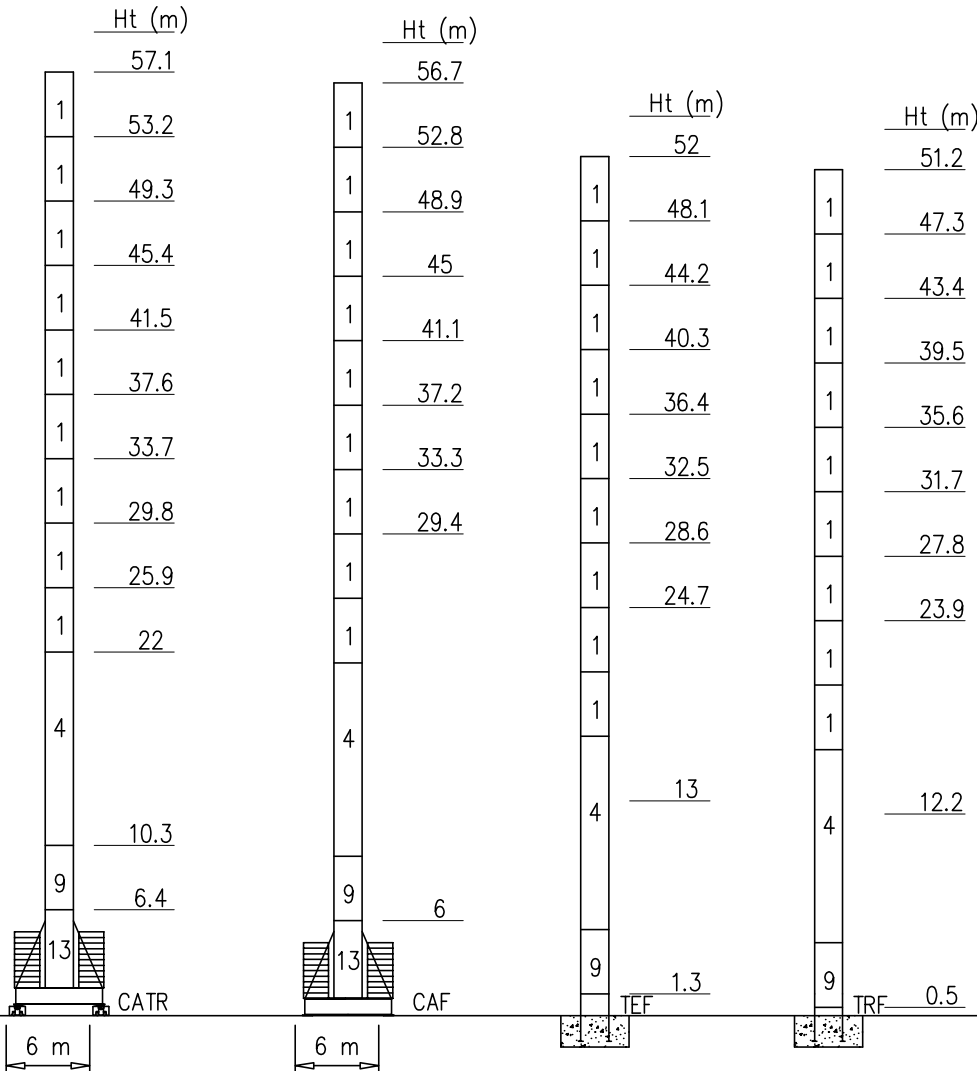

Peso zavorra – Ballast weight – Poids du lest – Ballastgewicht – Peso de lastre

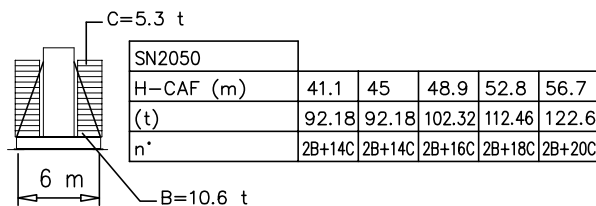
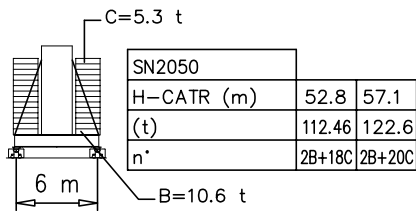

Torre/Reazioni - Masts/Reactions - Mat/Réactions - Maste/Eckdrücke - Măstil/Reacciones - Tramo/Reaçções

SN2050 EN14439-D25

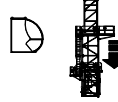
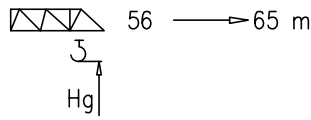

- Hg=Ht-1 m
- Hg=Ht-1.8 m

14	BCF052	2/4 M45
13	BAF052	2/4 M42
12	BPF117	4/4 M45-45
11	BNF117	4/4 M45-42
10	BOF117	4/4
9	BOF039	4/4
8	BO039	4/4
7	STRO39	2/2
6	SBR117	4/2
5	SBR039	4/2
4	SB117	4/2
3	SB039	4/2
2	ST117	2/2
1	ST039	2/2

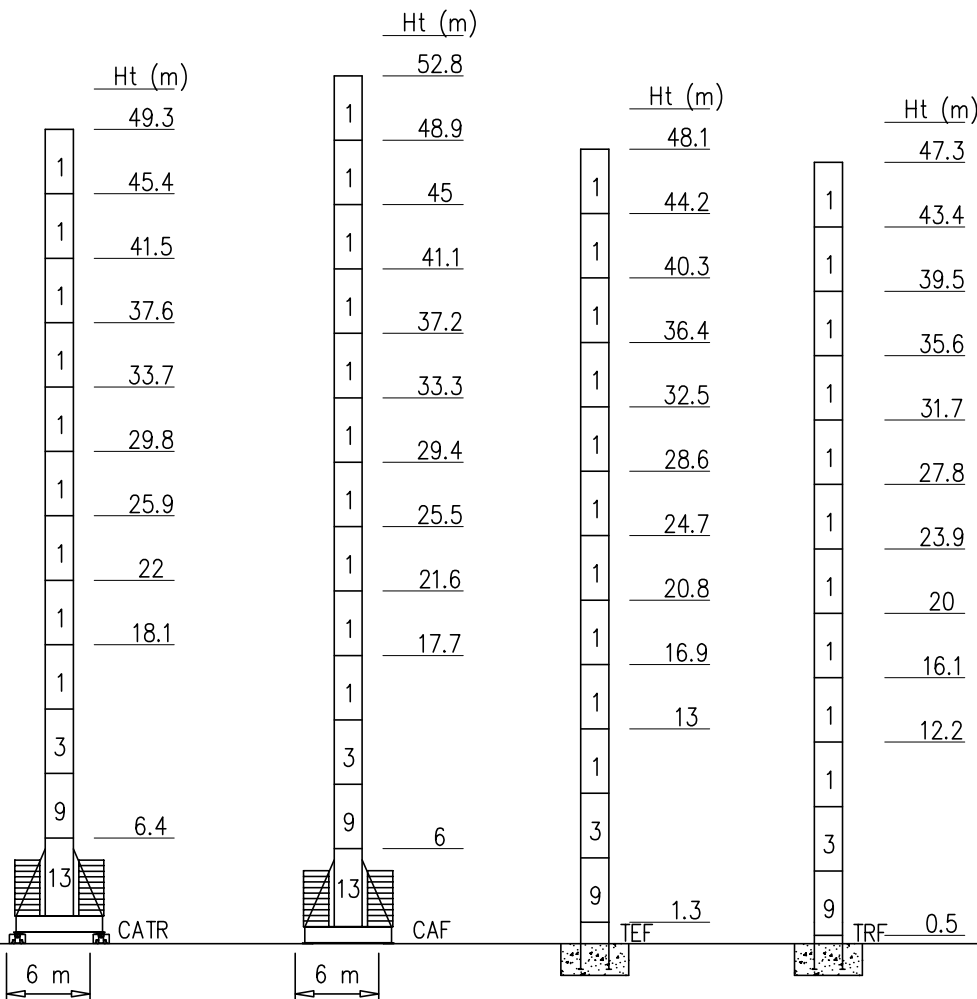

Peso zavorra - Ballast weight - Poids du lest - Ballastgewicht - Peso de lastre

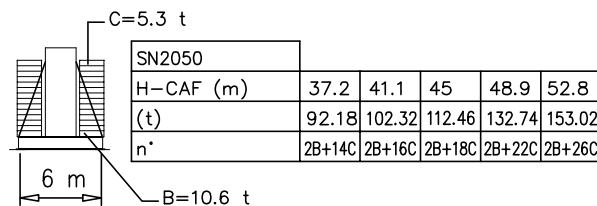
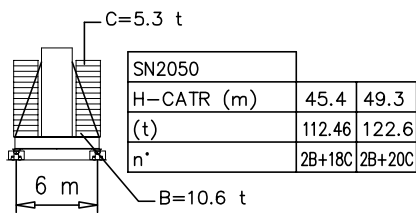

Curve di carico – Courbes de charges – Load diagrams – LastKurven – Curvas de cargas

Pmax 5000 kg

	25560 kg		3.5	22	26	30	34	36	38	40	42	44	46	48	50	52	54	56	58	60	63	65	m
		65 m	5000	5000	4050	3420	2950	2750	2570	2410	2260	2130	2010	1900	1800	1710	1620	1540	1470	1400	1200	1000	kg
	25560 kg		3.5	24.5	26	30	34	36	38	40	42	44	46	48	50	52	54	56	58	60	63	m	
		63 m	5000	5000	4050	3420	2950	2750	2570	2410	2260	2130	2010	1900	1800	1710	1620	1540	1470	1400	1300	kg	
	25560 kg		3.5		27.3	30	34	36	38	40	42	44	46	48	50	52	54	56	58	60	m		
		60 m	5000		5000	4050	3540	3210	2990	2800	2630	2480	2340	2210	2090	1990	1890	1800	1720	1700	kg		
	25560 kg		3.5		28.3	30	34	36	38	40	42	44	46	48	50	52	54	56	m				
		56 m	5000		5000	4830	4130	3840	3590	3300	3030	2870	2670	2540	2400	2300	2130	2000	kg				
	22720 kg		3.5		29.4	34	36	38	40	42	44	46	48	50	m								
		50 m	5000		5000	4470	4160	3890	3650	3430	3240	3060	2900	2500	kg								
	22720 kg		3.5		30.9	34	36	38	40	42	44	45	m										
		45 m	5000		5000	4470	4160	3890	3650	3430	3240	3100	kg										
	19880 kg		3.5		29.4	32	34	36	38	39	m												
		39 m	5000		5000	4830	4470	4160	3890	3500	kg												
	17040 kg		3.5		31.2	32	34	m															
		34 m	5000		5000	4830	4500	kg															

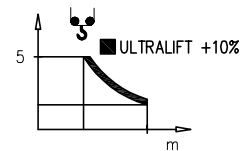





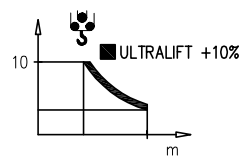





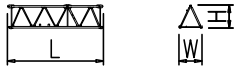

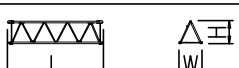
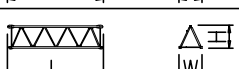
Pmax 10000/5000 kg

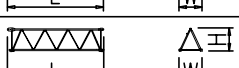
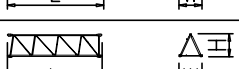

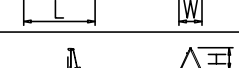

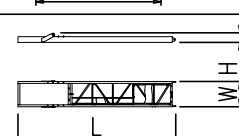
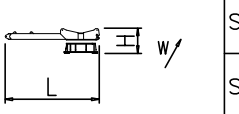

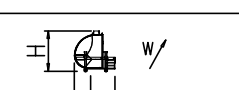



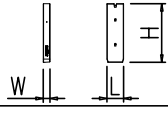

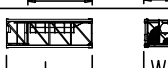

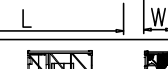

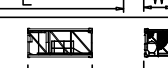

	25560 kg		3.5	12.4	20	22	26	30	34	36	38	40	42	44	46	48	50	52	54	56	58	60	63	65	m
		65 m	10000	10000	6360	5000	4050	3420	2950	2750	2570	2410	2260	2130	2010	1900	1800	1710	1620	1540	1470	1400	1200	1000	kg
	25560 kg		3.5	13.7	20	22	26	30	34	36	38	40	42	44	46	48	50	52	54	56	58	60	63	m	
		63 m	10000	10000	6360	5000	4050	3420	2950	2750	2570	2410	2260	2130	2010	1900	1800	1710	1620	1540	1470	1400	1300	kg	
	25560 kg		3.5	15.2	20	24	26	30	34	36	38	40	42	44	46	48	50	52	54	56	58	60	m		
		60 m	10000	10000	6870	5400	4870	4050	3540	3210	2990	2800	2630	2480	2340	2210	2090	1990	1890	1800	1720	1700	kg		
	25560 kg		3.5	15.8	20	22	26	30	34	36	38	40	42	44	46	48	50	52	54	56	m				
		56 m	10000	10000	8420	7180	5790	4830	4130	3840	3590	3300	3030	2870	2670	2540	2400	2300	2130	2000	kg				
	22720 kg		3.5	16.4	20	22	26	30	34	36	38	40	42	44	46	48	50	m							
		50 m	10000	10000	9500	7880	6260	5230	4470	4160	3890	3650	3430	3240	3060	2900	2500	kg							
	22720 kg		3.5	17.2	20	22	26	30	34	36	38	40	42	44	45	m									
		45 m	10000	10000	9500	7880	6260	5230	4470	4160	3890	3650	3430	3240	3100	kg									
	19880 kg		3.5	16.4	20	22	26	28	30	32	34	36	38	39	m										
		39 m	10000	10000	9500	7880	6260	5700	5230	4820	4470	4160	3890	3500	kg										
	17040 kg		3.5	17.4	20	22	26	28	30	32	34	m													
		34 m	10000	10000	9500	7880	6260	5700	5230	4820	4500	kg													

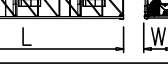
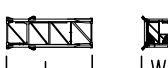

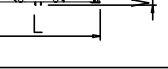
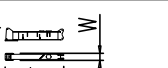
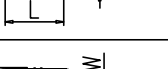
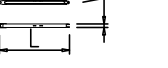
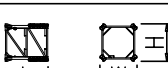
PESI E INGOMBRI – PACKING LIST – LISTE DE COLISAGE – GEWICHT UND ABMESSUNGEN

Denominazione Description	Disegno Draw	Pezzi Pieces	Dimensioni-Dimensions (mm)			Peso-Weight (kg)		
			L	W	H	Unit	Total	
Elemento di braccio Jib element Elément de èche Elemento de flecha	n°1 	1	5760	1440	1600	950	–	
	n°2 	1	5820	1400	1470	750	–	
	n°3 	1	5860	1400	1470	810	–	
	n°4 	1	5860	1400	1470	730	–	
	n°5 	1	5860	1400	1470	740	–	
	n°6 	1	5850	1400	1470	700	–	
	n°7 	1	5820	1400	1470	680	–	
	n°8 	1	5820	1400	1470	740	–	
	n°9 	1	5850	1400	1450	520	–	
	n°10 	1	5740	1400	1450	410	–	
	n°11 	1	5770	1400	1450	330	–	
	n°12 	1	4350	1400	1450	320	–	
	Punta 	1	800	1400	1400	170	–	
Tirante completo Complete tie rod Tirant complète Tirante completo		12	6500	200	200	240	3540	
Cuspide Cusp Pointre Cùspide		1	8300	1500	1000	2700	–	
Contorbraccio completo Complete counterjib Contreflèche complète Contraflecha completa		1	9300	1650	600	2000	–	
Gruppo girevole Slewing group Table tournante Grupo giratorio		SK1700	1	5100	1810	1400	6000	–
		SN2050	1	5100	1810	1400	6300	–
Carrello Trolley Chariot Carretilla		1	1900	1620	1000	400	–	
Ballatoio con cabina Access balcony with cabin Porte cabine Balcòn corrido con cabina		1	2500	2150	2450	1000	–	

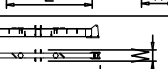
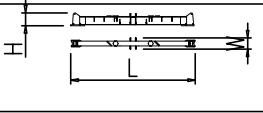
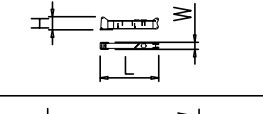
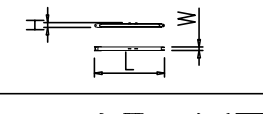
PESI E INGOMBRI – PACKING LIST – LISTE DE COLISAGE – GEWICHT UND ABMESSUNGEN

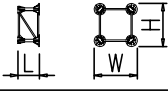
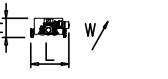
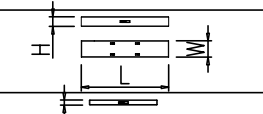
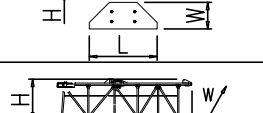
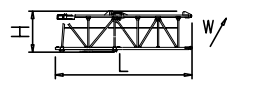
Denominazione Description	Disegno Draw	Pezzi Pieces	Dimensioni-Dimensions (mm)			Peso-Weight (kg)		
			L	W	H	Unit	Total	
Blocchi contrappeso Counterweight block Contre-poids Bloques de contrapeso	VX28 	9	1100	280	3700	2840	25600	
Elemento di torre Mast element Elément de mât Elemento de torre	ST039 	SK1700	-	3900	1785	1785	1750	-
	STR039 	SN2050	-	3900	2110	2110	2320	-
	ST052 	SK1700	-	5200	1785	1785	2250	-
	ST052 	SN2050	-	5200	2110	2110	2850	-
	ST117 	SK1700	-	11700	1785	1785	4690	-
	ST117 	SN2050	-	11700	2110	2110	5790	-
	SB039 	SK1700	-	3900	1785	1785	2100	-
	SB039 	SN2050	-	3900	2110	2110	2710	-
	SB052 	SK1700	-	5200	1785	1785	2600	-
	SB052 	SN2050	-	5200	2110	2110	3350	-
	SB117 	SK1700	-	11700	1785	1785	4830	-
	SB117 	SN2050	-	11700	2110	2110	7000	-
BOF039 	SK1700	-	3900	1785	1785	2450	-	
BO039 	SN2050	-	3900	2110	2110	3370	-	
BOF052 	SK1700	-	5200	1785	1785	3390	-	
BOF052 	SN2050	-	5200	2110	2110	3880	-	
BOF117 	SK1700	-	11700	1785	1785	6920	-	
BNF117 	SN2050	-	11700	2110	2110	8180	-	
BOF117 	SK1700	-	11700	1785	1785	6920	-	
BNF117 	SN2050	-	11700	2110	2110	8180	-	
Elemento di base Base element Mat de base Elemento de base	BAF052 	SK1700	1	5200	2060	2060	3650	-
	BCF052 	SN2050	1	5200	2260	2260	4040	-
Carro di base Base carriage Chassis de base Cruceta de base		4.5x4.5	1	6670	500	1260	3180	3180
		5x5	1	7550	670	780	2300	2300
		6x6	1	8870	670	780	2500	2500
		4.5x4.5	2	3100	500	1260	1400	2800
		5x5	2	3530	420	780	1060	2120
		6x6	2	4320	420	780	1200	2400
Puntoni di base Rafter Jambes de force Cabrios de base		5x5	4	4250	240	300	280	1120
		6x6	4	4560	420	300	420	1680
Elemento a perdere Disposable frame Chassis a perdre Bastidor desechable		SK1700	1	1840	1910	1910	1430	-
		SN2050	1	2600	2260	2260	2030	-
Elemento recuperabile Recoverable frame Chassis récupérable Bastidor recuperable		SK1700	1	1300	2170	2170	1720	-
		SN2050	1	1300	2620	2620	1860	-
Bogie di traslazione Driven bogie Boggie motorisée Balancin de traslaciòn			4	1160	700	600	700	2800
Blocco zavorra di base Base ballast block Lest de base Bloque de lastre		4.5x4.5	-	4400	1200	290	3500	-
		5x5	2	5300	1000	600	7300	14600
		5x5	-	4100	1600	300	3500	-
		6x6	-	4800	2000	300	5070	-
Corsoio di montaggio Climbing cage Cage de montage Jaula de montaje		SK1700	1	8300	2600	2500	6000	-
		SN2050	1	8300	2900	2700	6700	-

GRU IN CAVEDIO – TELESCOPAGE SUR DALLES – CLIMBING CRANE – KLETTERKRANE IM GEBAUDE

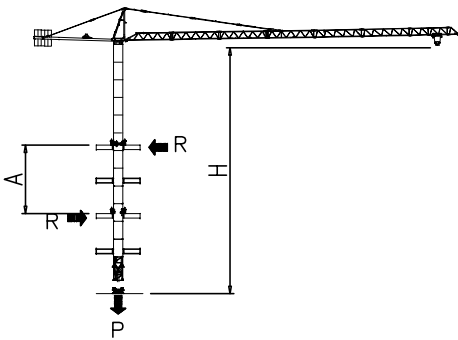

SK1700	H (m)	A (m)
	39	Min 9
		Max 12

Apertura passaggio gru
Opening for crane passing

SN2050	H (m)	A (m)
	50.8	Min 9
		Max 12

Apertura passaggio gru
Opening for crane passing

SOPRALZO IDRAULICO – TELESCOPABLE – EXTERNAL CLIMBING – KLETTERKRANE

FEM

	SK1700
MAX C	32.5 m
B	19.5 m
A	46.8 m

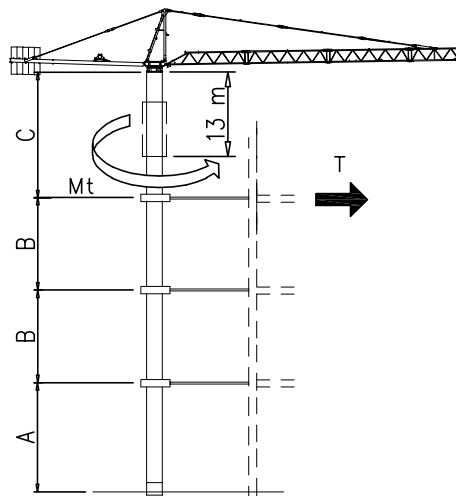



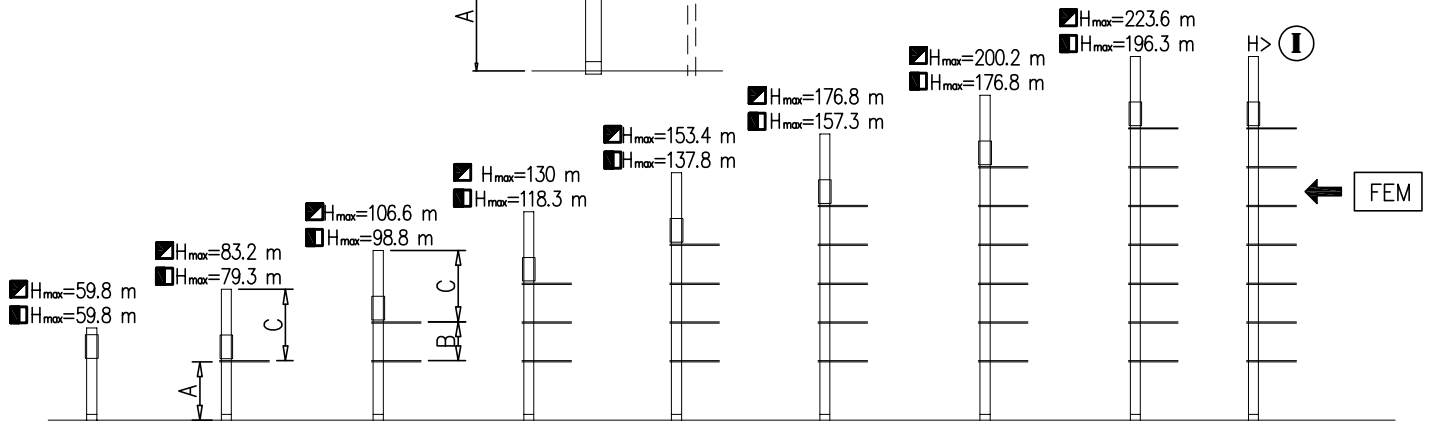



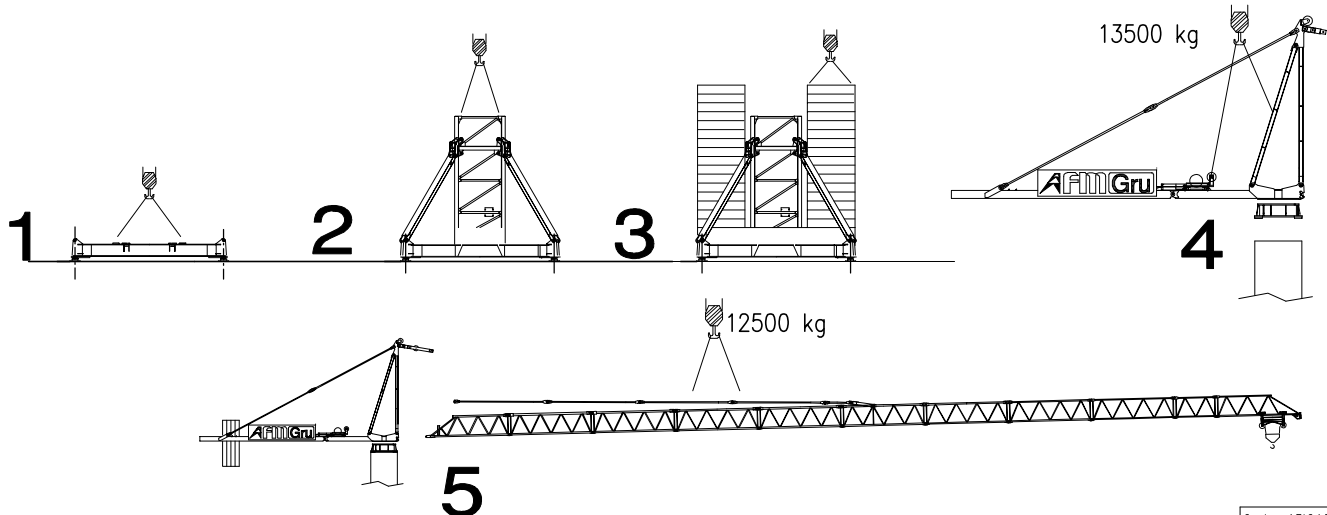

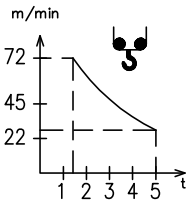
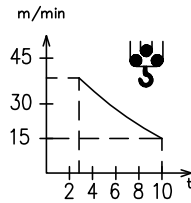
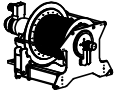
	SN2050
MAX C	36.4 m
B	23.4 m
A	46.8 m

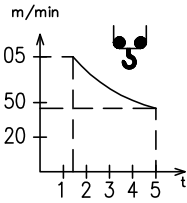
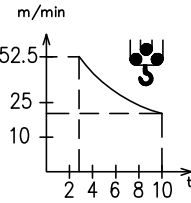
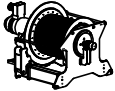

Montaggio – Montage – Erection – Montage – Montaje – Montagem

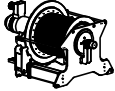
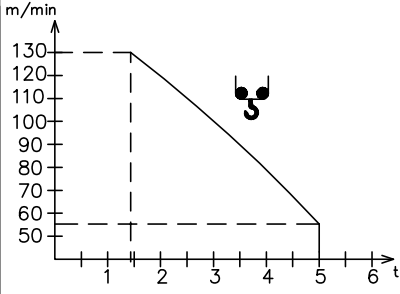
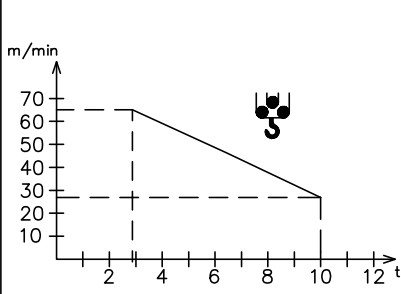

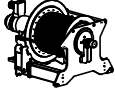
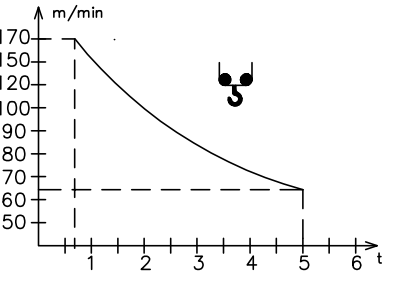
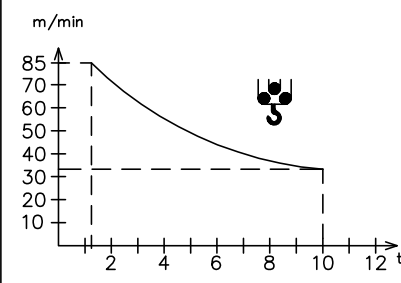
Sollevamento V45.60 Hoisting Levage Heben Elevaciòn Elevaçao									V45.60 33 kW 57 kVA  270 m 500 m (L)					
	m/min	3	14	30	45	60				72				
	t	5	5	5	3.5	2.4	1.4							
														
	m/min	1.5	7	15	22.5	30	36							
t	10	10	10	7	4.8	2.8								
Sollevamento V75.105 Hoisting Levage Heben Elevaciòn Elevaçao									V75.105 55 kW 80 kVA  260 m 520 m (L)					
	m/min	4	20	40	63	78				105				
	t	5	5	5	3.7	2.8	1.7							
														
	m/min	2	10	20	31.5	39	52.5							
t	10	10	10	7.4	5.6	3.4								
Sollevamento V100.130 Hoisting Levage Heben Elevaciòn Elevaçao													V100.130 75 kW 110 kVA  360 m 750 m (L)	
	m/min	5	28	54	86	115	130	3	14	27	43	57		65
	t	5	5	5	4	2.8	1.4	10	10	10	8	5.6		2.8
														
Sollevamento V100.170 Hoisting Levage Heben Elevaciòn Elevaçao													V100.170 75 kW 110 kVA  388 m 776 m (L)	
	m/min	7	35	67	107	147	170	3.5	17.5	33.5	53.5	73.5		85
	t	5	5	5	2.5	1.6	0.6	10	10	10	5	3.2		1.2
														

Sollevamento V170.220 Hoisting Levage Heben Elevaciòn Elevaçao														V170.220 125 kW 150 kVA 388 776 m (L)
	m/min	7	40	90	135	170	220	3.5	20	45	67.5	85	110	
	t	5	5	5	4	3.1	1.5	10	10	10	8	6.2	3	

Carrello Trolleying Distribution Katzfahren Distribuciòn Distribuiçao			0 → 85	m/min	3.6 kW	Potenza elettrica necessaria Puissance électrique nécessaire Necessary electric power Anschlusswert – Potencia
Rotazione Slewing Orientation Schwenken Orientaciòn Rotaçao			0 → 0,9	giri/min tr/min rp/min	4.4 kW @ 1200rpm n° 2 x 2.2 kW	
Traslazione Travelling Translation Kranfahren Traslaciòn Traslaçao			0 → 20	m/min	7.5 kW	

Rete elettrica – Réseau – Mains supply – Netzstrom – Red – Rede electrica	400V – 50 Hz
---	--------------

Rete elettrica – Réseau – Mains supply – Netzstrom – Red – Rede electrica	400V – 50 Hz
---	--------------

AFM Gru FMgru s.r.l.
 Via Emilia 11-29010 Pontenure PC ITALY
 tel. 0523/510446 ric.aut. fax 0523/510365
 www.fmgru.it e-mail: info@fmgru.com

FEM 1.001 – A4
 EN 14439 – C25 – D25



Documento commerciale non contrattuale
 Per tutte le informazioni tecniche riferirsi
 alle corrispondenti istruzioni

Unverbindliches Vertriebsdokument.
 Für technische Informationen, siehe die
 entsprechenden Anweisungen.

This commercial document is not legally
 binding. For any technical information, please
 refer to the corresponding instructions.

Documento comercial no contractual
 Para cualquier información técnica,
 ver la noticia correspondiente.